

## Hydraulic Mobile Tipper

### Hydraulic Mobile Tipper for 200 Litre Tote Bins

BTH/250/1060/M/G

#### Hydraulic Mobile Tipper Description

The hydraulic mobile tipper is designed to lift and tip a standard 200 Litre tote bin at a height of 1060mm. The hydraulic mobile tipper is constructed from Grade 304 stainless steel and is a fully TIG welded construction throughout. This hydraulic mobile tipper would be powered via a hydraulic power pack and would tip the containers by the extension of a stainless steel hydraulic cylinder. The hydraulic mobile tipper will operate on a 'dead mans handle' principle and is mobile on two fixed and two swivel braked castors. The hydraulic cylinder will be fitted with a hydraulic fuse to prevent the bin from falling in the unlikely event of a hose failure.



*Hydraulic Mobile Tipper for 200 Litre Tote Bin  
Guarded with Tipping Chute*

Call now on **01495 312 172**

[webenquiry@basehandling.co.uk](mailto:webenquiry@basehandling.co.uk)

Base Handling Products Limited, Unit 20, Barleyfield Industrial Estate  
Brynmawr, Gwent, NP23 4YF.



**Safety Guard to PD 5304:2005 Safety of Machinery**

The safety guard is constructed from 40 x 40 x 3mm stainless steel box section and 3mm wire, 40mm aperture stainless steel weld mesh to meet the requirements of PD 5304:2005 Safety of Machinery. It would enclose the hydraulic mobile tipper to a height of 2200mm on two sides, 800mm at the front with a hinged door on the fourth side. The guard door is electrically and mechanically interlocked preventing the hydraulic mobile tipper from operating with the door open. In addition, the guard door can only be opened when the lifting carriage is at the full down position.

**Hydraulic Mobile Tipper Specification**

DESCRIPTION	HYDRAULIC MOBILE TIPPER
MODEL NO.	BTH/250/1060/M/G
CAPACITY	250Kgs
TIPPING HEIGHT	1060mm
TIPPING ANGLE	120 DEGREES
MACHINE HANDING	LEFT OR RIGHT HAND AVAILABLE
TIPPING CHUTE	OPTIONAL
CONTAINER DESCRIPTION	STANDARD 200 LITRE TOTE BIN
BASE ARRANGEMENT	MOBILE ON CASTORS
CONTROL CIRCUIT	24Vac (STANDARD)
ELECTRICAL RATING	IP65
POWERPACK	415V, 50 Hz, 3 PHASE & NEUTRAL

**Hydraulic Mobile Tipper Application Story**

This hydraulic mobile tipper was required to load ingredients into a dough mixing vessel through a hatch at the end of the vessel. It was fully guarded to that the lift and tip operation could be automated. The long narrow chute was required to direct the ingredients into a small hatch aperture and it therefore tapers down to only 300mm at the end

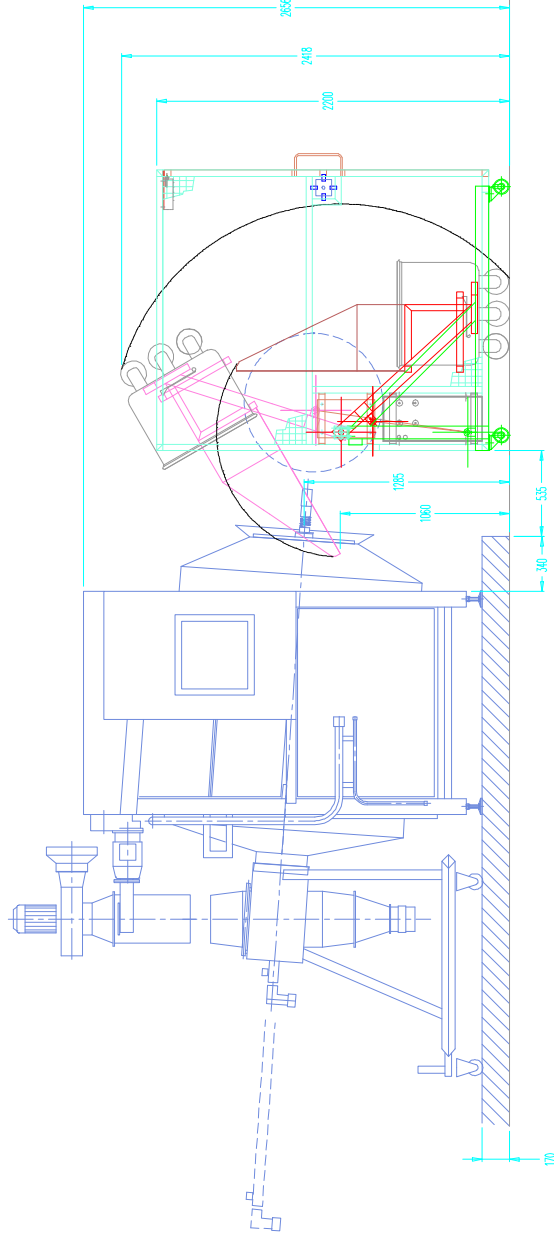
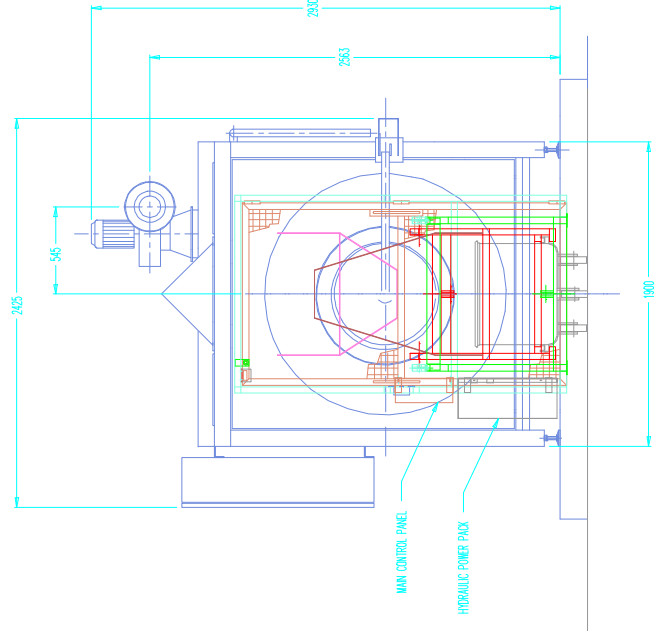
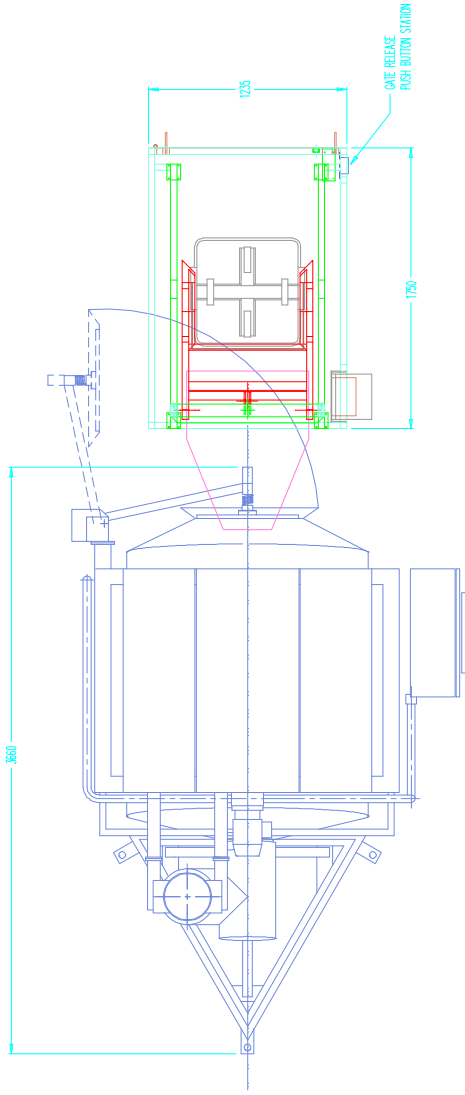

**BASE HANDLING PRODUCTS LTD (Copyright Reserved)**

Units 19-21, Bleanau Gwent Workshops,  
Pond Road,  
Brynmawr, Gwent NP23 4RL  
TEL: (01495) 312172 FAX: (01495) 312089 email: info@baseproducts.co.uk

Revision Number:

Customer:

Checked:

Date: 03-09-02

Drawn: JPW

Drawing Number:

BP2446-1

HYDRAULIC 200 LITRE TOTE BIN TIPPER  
MOBILE GUARDED

Drawing Title: