

## Tote Bin Lift

### Single Pillar Tote Bin Lift for 200 Litre Tote Bins

BTM/250/2700-3700/B

#### Tote Bin Lift Description

The tote bin lift is a single pillar 200 Litre tote bin tipper that is designed to lift and tip at an adjustable discharge height of between 2700mm and 3700mm in 100mm increments. The tote bin lift is constructed from Grade 304 stainless steel, is fully TIG welded throughout and will operate on a 'dead mans handle' principle. Lifting with the tote bin lift is achieved by a 3/4" Simplex chain driven by a motor gearbox mounted at the top of the main column. The tote bin lift is designed to be bolted to the floor.



*Tote Bin Lift for 200 Litre Tote Bin*

Call now on 01495 312 172

[webenquiry@basehandling.co.uk](mailto:webenquiry@basehandling.co.uk)

Base Handling Products Limited, Unit 20, Barleyfield Industrial Estate  
Brynmawr, Gwent, NP23 4YF.



**Tote Bin Hoist Specification**

DESCRIPTION	SINGLE PILLAR TOTE BIN LIFT
MODEL No.	BTM/250/2700-3700/B
CAPACITY	250Kgs
ADJUSTABLE TIPPING HEIGHT	2700 - 3700mm
TIPPING ANGLE	130 DEGREES
OVERALL HEIGHT	4615mm
MACHINE HANDING	LEFT OR RIGHT HAND AVAILABLE
TIPPING CHUTE	OPTIONAL
CONTAINER DESCRIPTION	STANDARD 200 LITRE TOTE BIN
BASE ARRANGEMENT	BOLTED TO THE FLOOR
CONTROL CIRCUIT	24Vac (STANDARD)
ELECTRICAL RATING	IP65
LIMIT SWITCHES	ADJUSTABLE ROD
MOTOR DETAIL	0.55kW, 415V, 3 PHASE, 50 CYCLE
MOTOR BRAKE	415V SEPARATELY EXCITED
GEARBOX DETAIL	FLENDER D38 M1P4D7.5
OUTPUT R.P.M.	28 R.P.M.
RATIO	50:1
LOAD/TENSION CHAIN	¾" SIMPLEX DELTA Z
TENSILE STRENGTH	3000Kgs
LIFT SPEED	6.4 METERS/MINUTE

**Tote Bin Lift Application Story**

This tote bin lift was designed to lift and tip the contents of a 200 Litre tote bin but the discharge height can be varied by unbolting and moving the tipping cam. This allowed a variation in the tipping height of between 2700mm and 3700mm in 100mm increments.

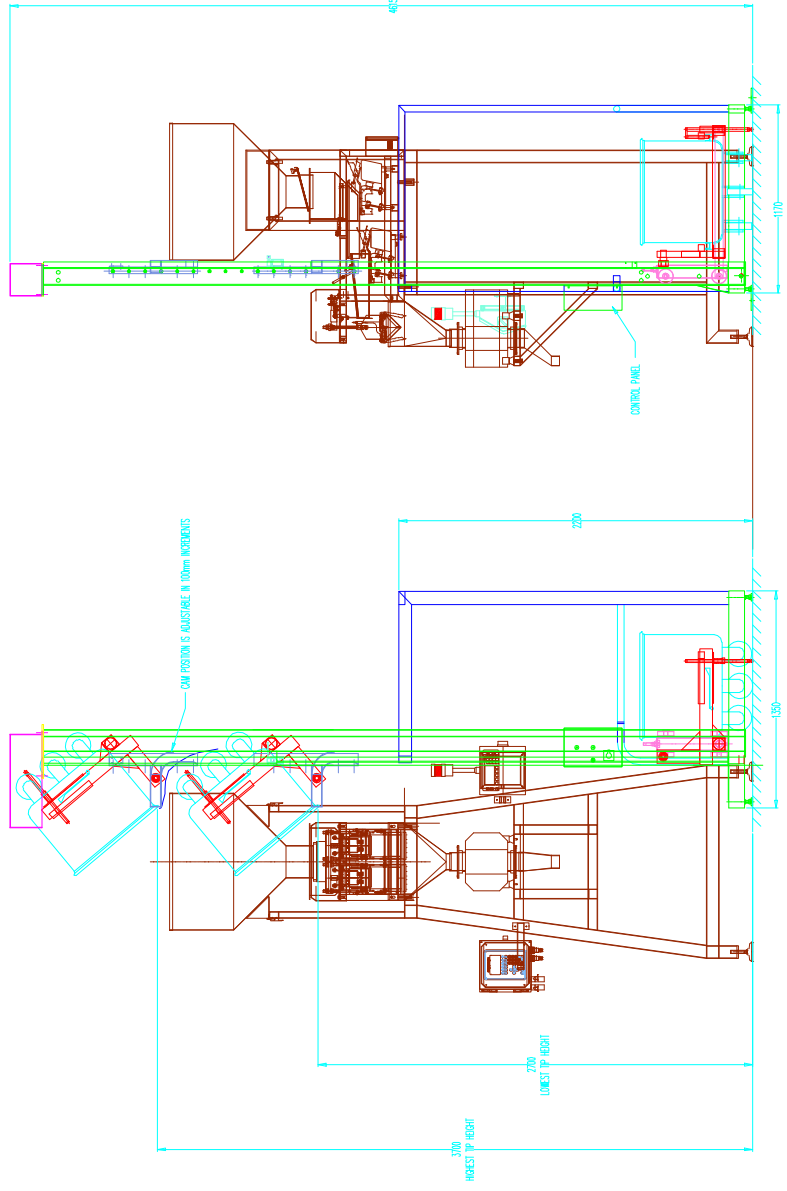
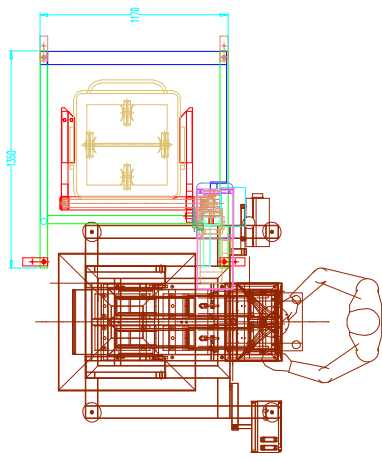

COPYRIGHT RESERVED  
 DRAWN THIRD ANGLE PROJECTION



**BASE HANDLING PRODUCTS LIMITED**  
 UNIT 20 BARLETFIELD INDUSTRIAL ESTATE,  
 BRYNMAWR,  
 GWENT, NP23 4TF  
 TEL: (01495) 312172 FAX: (01495) 312089 EMAIL: info@baseproducts.co.uk

REVISION NUMBER  
 CUSTOMER

DRAWING TITLE  
 SINGLE PILLAR 200 LITRE TOTE BIN TIPPER  
 BOLTED ADJUSTABLE TIP HEIGHT

REMOVE ALL BURRS AND SHARP EDGES  
 TOLERANCES : UNLESS OTHERWISE STATED  
 FABRICATIONS : +/- 2.0mm  
 MACHINING : +/- 0.2mm  
 SHEET METAL WORK : +/- 1.0mm AND +/- 1.0 DEG

DRAWN JPW  
 CHECKED  
 DATE 16-11-06

DRAWING NUMBER  
 BP3167-1