

## Static Drum Tipper

### Single Pillar Static Drum Tipper for 200 Litre Drums

BTM/250/2200/B

#### Static Drum Tipper Description

This static drum tipper is a single pillar 200 Litre drum tipper that is designed to lift and tip at a discharge height of 2200mm. The static drum tipper is constructed from Grade 304 stainless steel, is fully TIG welded throughout and will operate on a 'dead mans handle' principle. Lifting with the static drum tipper is achieved by a 32mm diameter screw driven by a motor gearbox mounted at the top of the main column. The static drum tipper is mounted on a 10mm base plate which is bolted to the floor using M16 countersunk set screws and chemical anchor bolts.

To load the static drum tipper the operator will bring the pallet full of ingredients into the room and position the pallet in close proximity to the lift carriage. The base of the lift carriage will be at the same height as the pallet. The drums on the pallet can now be slid from the pallet into the lift carriage and lifted and tipped. All other ingredients can then be decanted into the drum and lifted and tipped in the same manner. The static drum tipper will accommodate various different size drums.



*Static Drum Tipper for 200 Litre Drums*

Call now on 01495 312 172

[webenquiry@basehandling.co.uk](mailto:webenquiry@basehandling.co.uk)

Base Handling Products Limited, Unit 20, Barleyfield Industrial Estate  
Brynmawr, Gwent, NP23 4YF.



**Static Drum Tipper Specification**

DESCRIPTION	SINGLE PILLAR STATIC DRUM TIPPER
MODEL No.	BTM/250/2200/B
CAPACITY	250Kgs
TIPPING HEIGHT	2200mm
TIPPING ANGLE	150 DEGREES
OVERALL HEIGHT	3200mm
MACHINE HANDING	LEFT OR RIGHT HAND AVAILABLE
TIPPING CHUTE	OPTIONAL
CONTAINER DESCRIPTION	VARIOUS DRUMS APPROX 200 LITRE VOLUME
BASE ARRANGEMENT	BOLTED TO THE FLOOR SIDE LOADING
CONTROL CIRCUIT	24Vac (STANDARD)
ELECTRICAL RATING	IP65
LIMIT SWITCHES	ADJUSTABLE ROD
MOTOR DETAIL	0.55kW, 415V, 3 PHASE, 50 CYCLE
MOTOR BRAKE	415V SEPARATELY EXCITED
GEARBOX DETAIL	FLENDER D38 M1P4D7.5
OUTPUT R.P.M.	28 R.P.M.
RATIO	50:1
LIFTING SCREW	32mm DIAMETER x 20mm PITCH
LIFT SPEED	6.4 METERS/MINUTE

**Static Drum Tipper Application Story**

This static drum tipper was designed for a Pharmaceutical/Food Processor to lift and tip the ingredients for a particular batch of product into a Bulk Bag. The Bulk Bag was attached to the underside of the stainless steel tipping chute and the drums of product were lifted and tipped into the bulk bag via the chute. The static drum tipper lifting frame was designed such that a large variety of different sized drums could be tipped using the same machine. The static drum tipper was a screw driven instead of the normal chain drive which suited the customers hygiene requirements better.

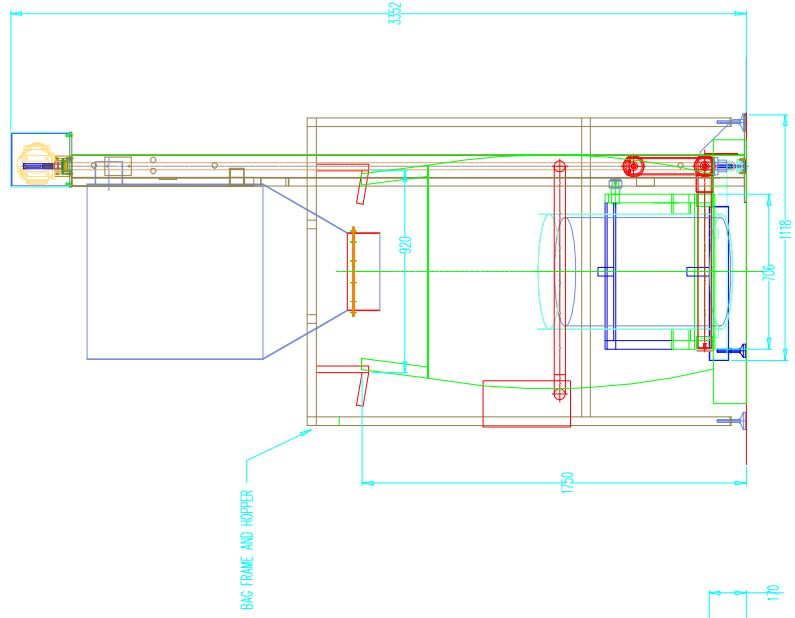
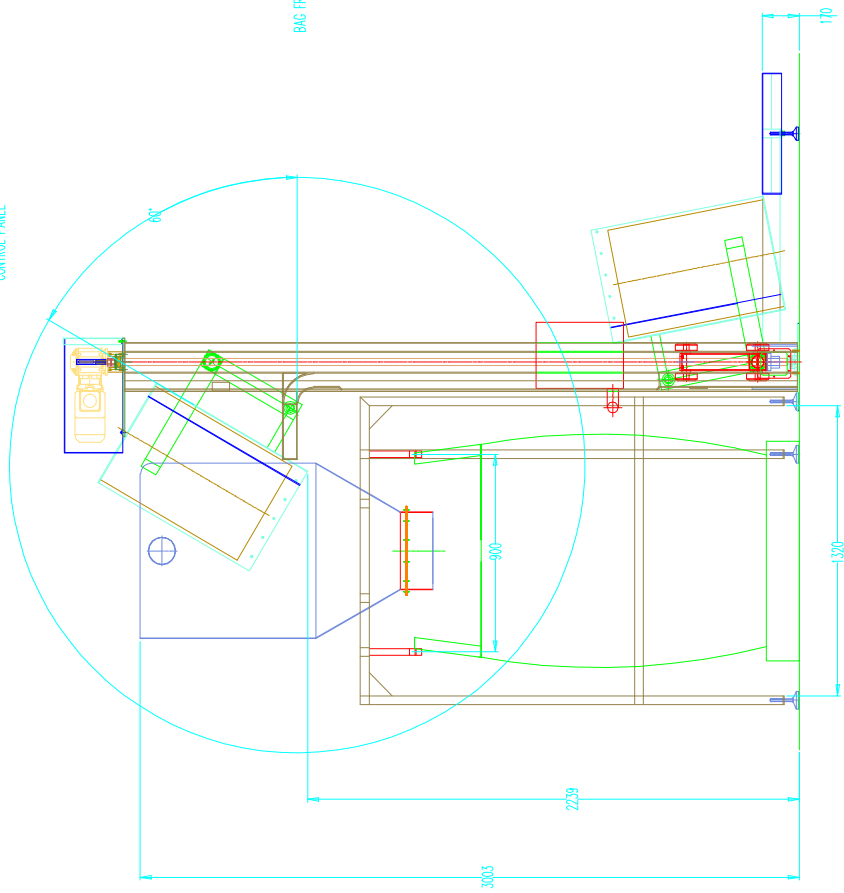
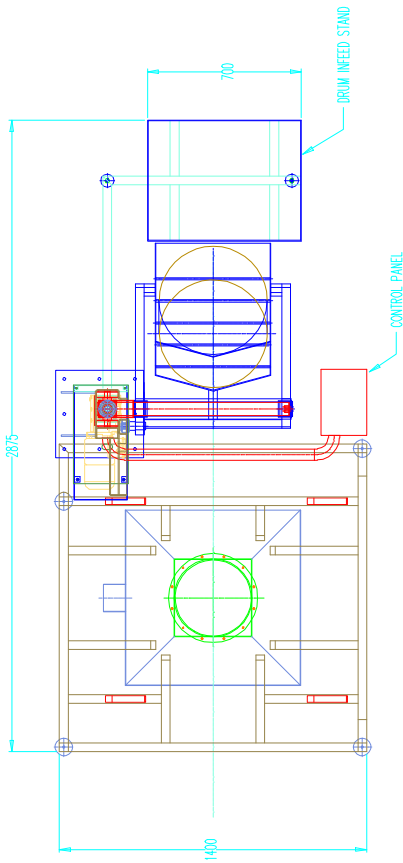

**BASE HANDLING PRODUCTS LIMITED**  
 UNIT 20 BARKETED INDUSTRIAL ESTATE,  
 BRIMINGHAM, WEST MIDLANDS, UK  
 TEL: (0121) 352121 FAX: (0121) 352188 EMAIL: [info@baseproducts.co.uk](mailto:info@baseproducts.co.uk)

DESIGNER  
 CUSTOMER

DRAWING TITLE

SINGLE PILLAR 2000 LITRE DRUM TIPPER  
 SCREW DRIVE BOLTED

REMOVE ALL SURFS AND SHARP EDGES  
 TOLERANCES: UNLESS OTHERWISE STATED  
 FINISHES: +/- 0.2mm  
 SURFACE FINISH: R0.8  
 SHEET METAL WORK: +/- 1.0mm AND +/- 0.5 DEG  
 DRAWN: JWB  
 CHECKED: JWB  
 DATE: 05-10-07  
 PROJECT NO: BP3222-1

