

Mobile Drum Tipper

Single Pillar Mobile Drum Tipper for 200 Litre Drums BTM/250/1250/M

Mobile Drum Tipper Description

The mobile drum tipper is a single pillar 200 Litre steel drum tipper that is designed to lift and tip at a discharge height of 1250mm. The mobile drum tipper is constructed from Grade 316 stainless steel, is fully TIG welded throughout and will operate on a 'dead mans handle' principle. Lifting with the mobile drum tipper is achieved by a $\frac{3}{4}$ " Simplex chain driven by a motor gearbox mounted at the top of the main column. The mobile drum tipper is designed to be mobile on two fixed and two swivel braked castors.



Mobile Drum Tipper for 200 Litre Drums

Call now on **01495 312 172**

webenquiry@basehandling.co.uk

Base Handling Products Limited, Unit 20, Barleyfield Industrial Estate
Brynmawr, Gwent, NP23 4YF.



Mobile Drum Tipper Specification

DESCRIPTION	SINGLE PILLAR MOBILE DRUM TIPPER
MODEL No.	BTM/250/1250/M
CAPACITY	250Kgs
TIPPING HEIGHT	1250mm
TIPPING ANGLE	130 DEGREES
OVERALL HEIGHT	2225mm
MACHINE HANDING	LEFT OR RIGHT HAND AVAILABLE
TIPPING CHUTE	OPTIONAL
CONTAINER DESCRIPTION	200 LITRE DRUM
BASE ARRANGEMENT	MOBILE ON CASTORS
CONTROL CIRCUIT	24Vac (STANDARD)
ELECTRICAL RATING	IP65
LIMIT SWITCHES	ADJUSTABLE ROD
MOTOR DETAIL	0.55kW, 415V, 3 PHASE, 50 CYCLE
MOTOR BRAKE	415V SEPARATELY EXCITED
GEARBOX DETAIL	FLENDER D31 M1P4D7.5
OUTPUT R.P.M.	28 R.P.M.
RATIO	50:1
LOAD/TENSION CHAIN	¾" SIMPLEX DELTA Z
TENSILE STRENGTH	3000Kgs
LIFT SPEED	6.4 METERS/MINUTE

Mobile Drum Tipper Application Story

This mobile drum tipper was designed to lift and tip a 200 Litre drum of sardines in brine into an elevator at the beginning of a fish processing line.

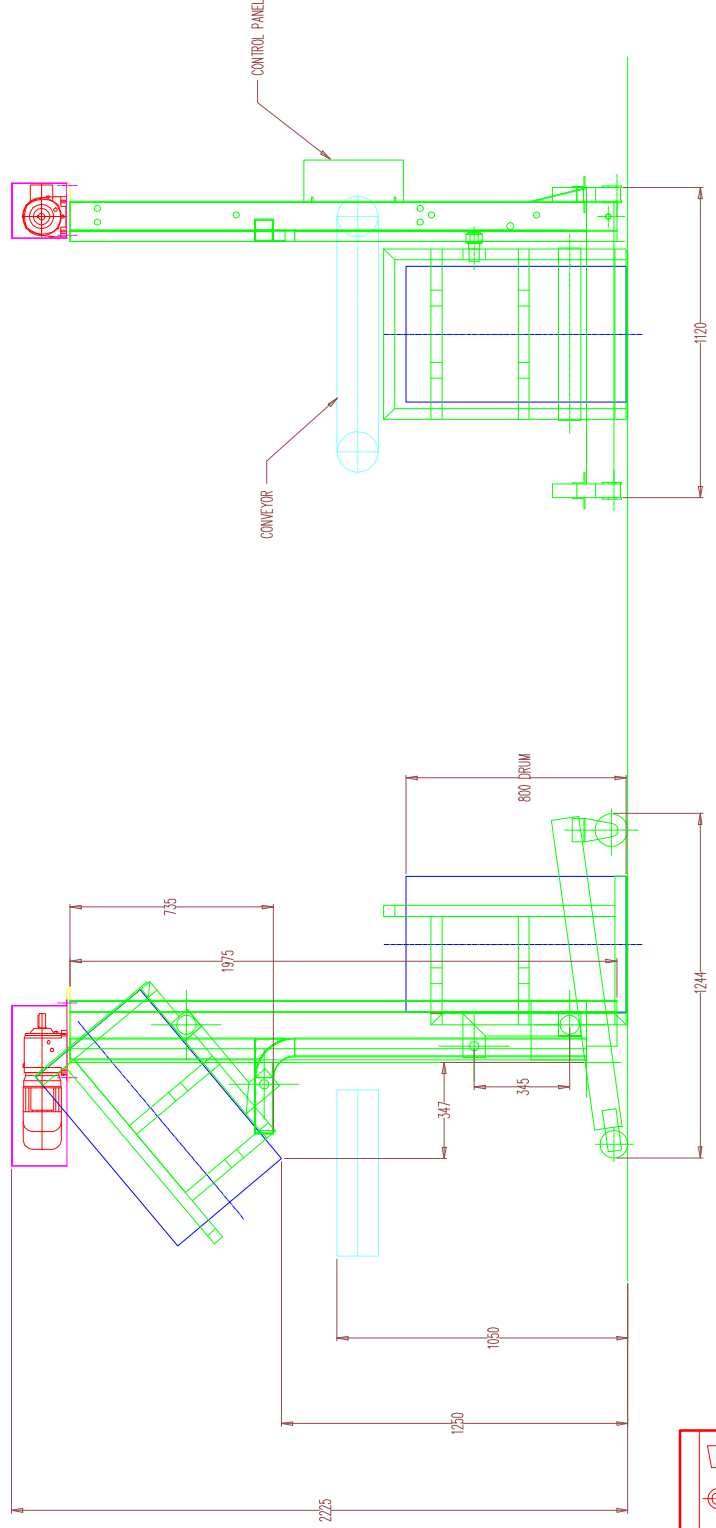
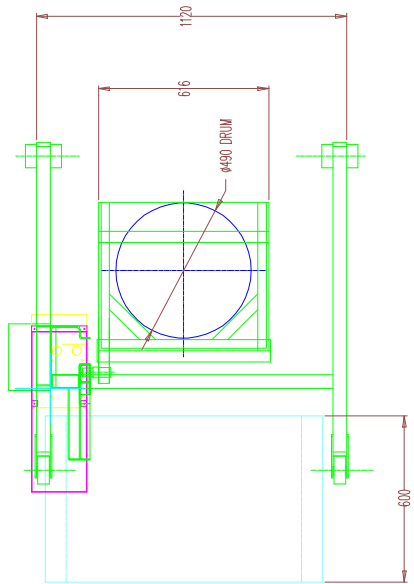

REMOVE ALL BURRS AND SHARP EDGES			
TOLERANCES : UNLESS OTHERWISE STATED			
FABRICATIONS : +/- 2.0mm			
MACHINING : +/- 0.2mm			
SHEET METAL WORK : +/- 1.0mm AND +/- 1.0 DEG			
DRAWN	CHECKED	DATE	
MRJ		26.01.04	
DRAWING NUMBER			BP2754-1

BASE HANDLING PRODUCTS LIMITED
 UNITS 19-20, BARLEYFELD INDUSTRIAL ESTATE,
 BRYNMAWR,
 GWENT, NP23 4LU
 TEL: (01495) 312172 FAX: (01495) 312089 EMAIL: info@baseproducts.co.uk

REVISION NUMBER	CUSTOMER
	SINGLE PILLAR 200 LITRE DRUM TIPPER MOBILE
DRAWING TITLE	

COPYRIGHT RESERVED
 DRAWN THIRD ANGLE PROJECTION