

200 Litre Stainless Steel Tote Bin

Stainless Steel Tote Bin for use in the Food & Pharmaceutical Industry

200 Litre Stainless Steel Tote Bin Description

The 200 Litre Stainless Steel Tote Bin was specially designed and developed for use in the Food and Pharmaceutical Industries which has dictated various features. The 200 Litre Stainless Steel Tote Bin has a 200 litre capacity, is mobile on nylon wheels and has strong stainless steel lifting lugs. The stainless steel lifting lugs allow the 200 Litre Stainless Steel Tote Bin to be lifted and tipped in standard bin tippers, including the tippers available from Base Handling Products.

In addition, the 200 Litre Stainless Steel Tote Bin is manufactured from stainless steel sheet and is a fully welded construction. The sides of the Stainless Steel Tote Bin are finished with a rolled edge to make the bin robust and give a hygienic finish. The Stainless Steel Tote Bin has a welded pushing handle which allows for easy wheeling and manoeuvring.



200 Litre Stainless Steel Tote Bin

Call now on **01495 312 172**

webenquiry@basehandling.co.uk

Base Handling Products Limited, Unit 20, Barleyfield Industrial Estate
Brynmawr, Gwent, NP23 4YF.





200 Litre Stainless Steel Tote Bin

200 Litre Stainless Steel Tote Bin Specification

DESCRIPTION	200 LITRE STAINLESS STEEL TOTE BIN
CAPACITY	200 LITRES
DIMENSIONS	676 x 695 x 700mm HIGH
WHEEL DIAMETER	150mm
MATERIAL OF CONSTRUCTION	STAINLESS STEEL GRADE 304 (GRADE 316 AVAILABLE ON REQUEST)
LIFTING LUGS	STAINLESS STEEL GRADE 304
LIDS	OPTIONAL EXTRA

200 Litre Stainless Steel Tote Bin Application Story

For the first time in the United Kingdom, the Stainless Steel Tote Bin is available with an electrolytically polished surface. In general, all stainless steel products and containers have surfaces which require a certain effort to clean. The polished surface of the Stainless Steel Tote Bin reduces the coarseness of the surface finish by up to 85%. This makes the Stainless Steel Tote Bin extremely hygienic and reduces the costs associated with cleaning including water, detergent and energy consumption.

DRAWING NUMBER
BP1562-1
© 2009 BACE HANDLING PRODUCTS LTD

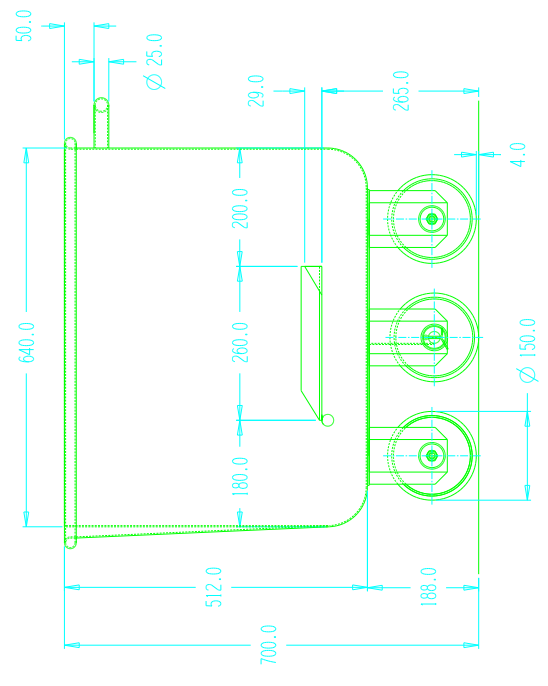
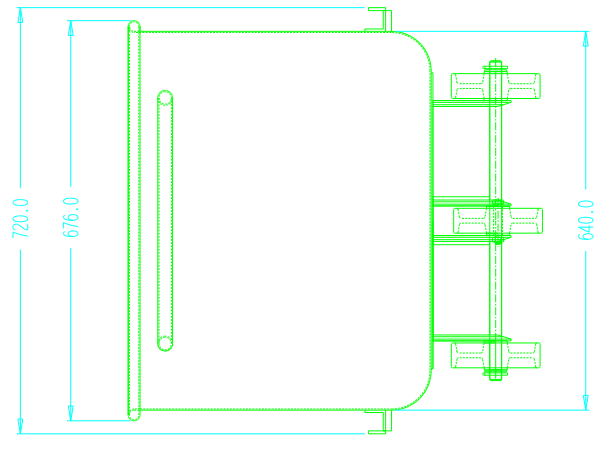
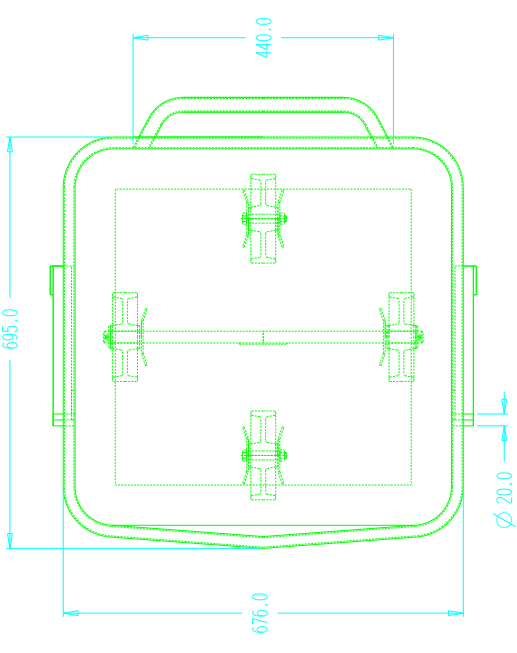

BACE HANDLING PRODUCTS LIMITED
 UNIT 10, BRIDGEFIELD INDUSTRIAL ESTATE,
 BURNWELL, N23 4HF
 TEL: (01865) 312172 FAX: (01865) 312088 EMAIL: enquiries@bacehandling.co.uk

ESTD IN NUMBER 1971 1975-06 PM
 DRAWING TO THE COMPANY'S
 CUSTOMER

DRAWING TITLE
 200 LTR TOTE BIN

REVISIONS: ALL DIMENSIONS AND SHARP EDGES
 TOLERANCES: UNLESS OTHERWISE STATED
 FINISHES: AS PER DRAWING
 SHEET METAL BOX: 1.5mm AND 1.0mm
 DRAWN THIRD ANGLE PROJECTION

DRAWN: JPN
 CHECKED: JPN
 DATE: 20-06-07
 DRAWING NUMBER: BP1562-1