

Hydraulic Mixer Lift

Hydraulic Mixer Lift

HML/150/455-1855/M

Manual Pump Up Hydraulic Mixer Lift Description

This hydraulic mixer lift is a manually operated lift that was designed to raise and lower a Ytron Mixer into a stainless steel vessel for mixing. The hydraulic mixer lift is constructed from Grade 304 stainless steel and is fully TIG welded throughout. The hydraulic mixer lift was mobile on two fixed and two swivel braked castors. The lifting arm is raised and lowered by the operation of a Manual Hydraulic Pump & Cylinder. At the optimum mixing height, the mixer was 455mm from the floor and to remove the mixer from the vessel, when the mixer was raised it was 1855mm from the floor. The mixer and vessel were interlocked so that the mixer dropped accurately into the vessel entry cover.



Hydraulic Mixer Lift

Call now on 01495 312 172

webenquiry@basehandling.co.uk

Base Handling Products Limited, Unit 20, Barleyfield Industrial Estate
Brynmawr, Gwent, NP23 4YF.



Hydraulic Mixer Lift Specification

DESCRIPTION	HYDRAULIC MIXER LIFT
MODEL No.	HML/150/455-1855/M
CAPACITY	150 Kgs
MINIMUM HEIGHT	455mm
MAXIMUM HEIGHT	1855mm
STROKE	1400mm
BASE ARRANGEMENT	MOBILE ON CASTORS
HYDRAULIC PUMP	MAJOR 17530

Hydraulic Mixer Lift Application Story

This ATEX Mixer Lift was required to raise and lower a Ytron Mixer into a drum in an ATEX environment. Once the mixer was lowered, various liquids and powders were added into the drum to be mixed. Once the mix was completed, the mixer was raised out of the drum using the hoist and the drum removed for further processing.

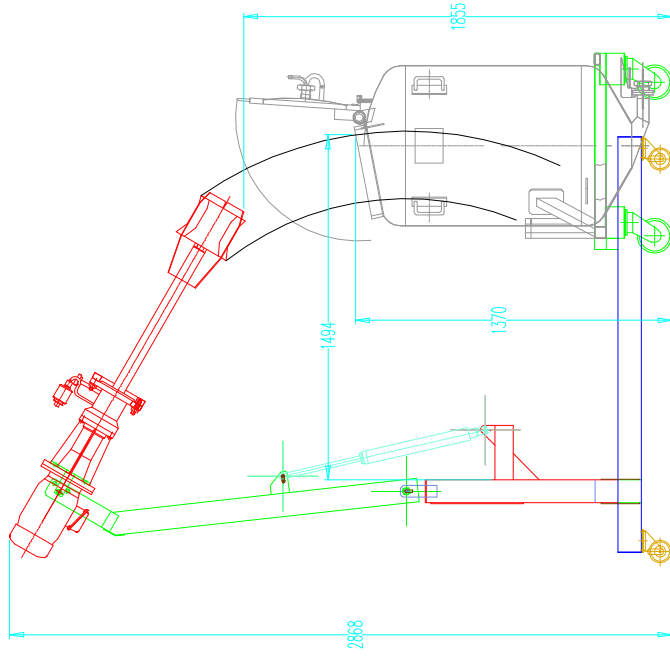
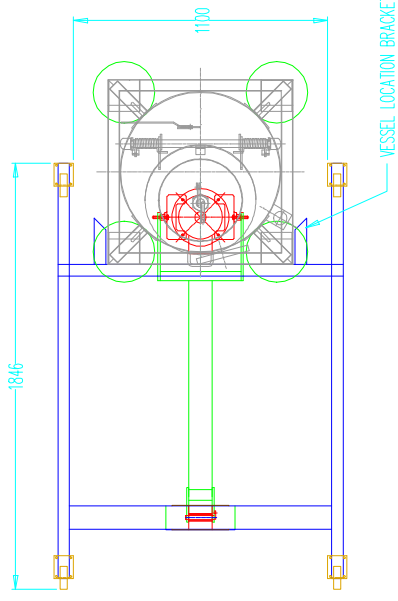

VIEW SHOWING FULLY EXTRACTED MIXER

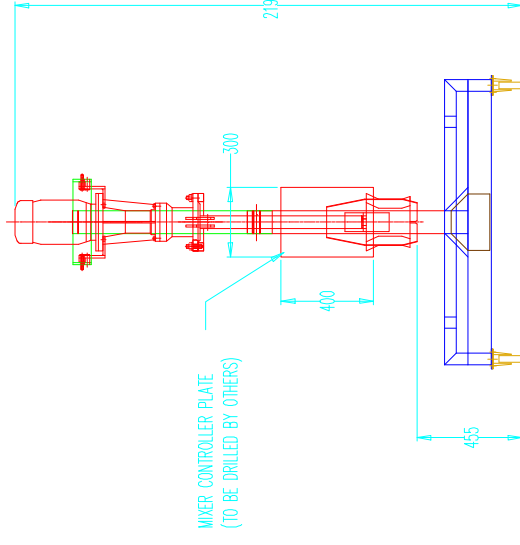

MIXER CONTROLLER PLATE
(TO BE DRILLED BY OTHERS)

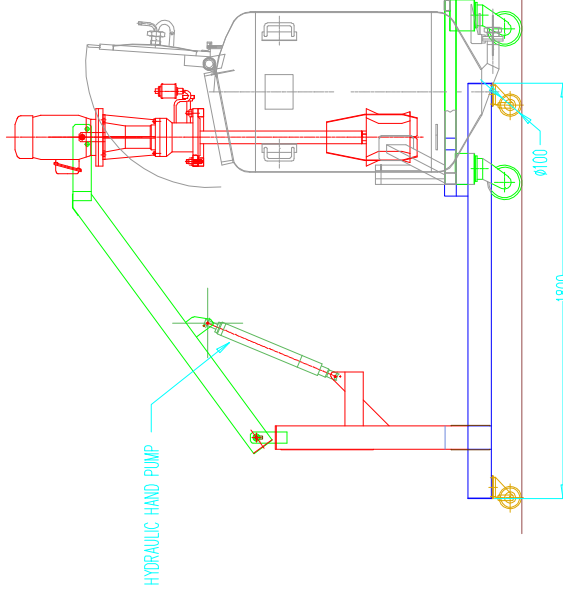

COPYRIGHT RESERVED

DRAWN THIRD ANGLE PROJECTION



BASE HANDLING PRODUCTS LIMITED
 UNIT 20 BARLEYFIELD INDUSTRIAL ESTATE,
 BRYNMAWR,
 GWENT, NP23 4TF
 TEL: (01495) 312172 FAX: (01495) 312089 EMAIL: info@baseproducts.co.uk

REMOVE ALL BURRS AND SHARP EDGES
 TOLERANCES : UNLESS OTHERWISE STATED
 FABRICATIONS : +/- 2.0mm
 MACHINING : +/- 0.2mm
 SHEET METAL WORK : +/- 1.0mm AND +/- 1.0 DEG

DRAWN JPW
 CHECKED
 DATE 17-07-06

DRAWING NUMBER
 BP3134-1

DRAWING TITLE

HYDRAULIC MANUAL PUMP UP MIXER LIFT

REVISION NUMBER

CUSTOMER