

Single Column Double Hopper Lift

Single Column Double Hopper Lift

MHL/200/100-1750/B

Single Column Double Hopper Lift Description

This single column double hopper lift is a manually operated Hopper Lift that was designed to lift two stainless steel hoppers of different design. The single column double hopper lift is constructed from Grade 304 stainless steel and is fully TIG welded throughout to a pharmaceutical environment standard. The lifting is achieved by a hand operated wheel driving through a bevel gearbox that rotated a lifting screw. For a quicker lifting and lowering time particularly when the hoppers was to be removed for cleaning, the lift could be operated by a battery drill. The single column double hopper lift was designed to be bolted to the floor. Once both hoppers were loaded onto the lifting arms, the operator could rotate either hopper into place above a blender depending on which product was being processed.



Single Column Double Hopper Lift

Call now on 01495 312 172

webenquiry@basehandling.co.uk

Base Handling Products Limited, Unit 20, Barleyfield Industrial Estate
Brynmawr, Gwent, NP23 4YF.



Hopper Lift Specification

DESCRIPTION	SINGLE COLUMN DOUBLE HOPPER LIFT
MODEL No.	MHL/200/100-1750/B
CAPACITY	200 Kgs
MINIMUM HEIGHT	100mm
MAXIMUM HEIGHT	1750mm
STROKE	1650mm
BASE ARRANGEMENT	BOLTED TO THE FLOOR

Hopper Lift Application Story

To prevent the risk of injury to operators who were lifting hoppers on and off a blender, the above hopper lift was designed to carry out the task in a safe manner. The hoppers were loaded onto the hopper lift at a low level and then raised using the screw driven lift to height of approximately 1750mm. The hopper could then be rotated above the blender and lowered to dock with a flexible coupling

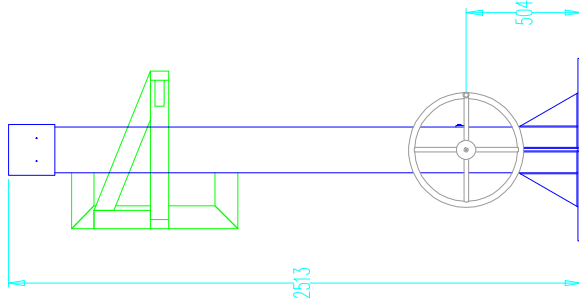
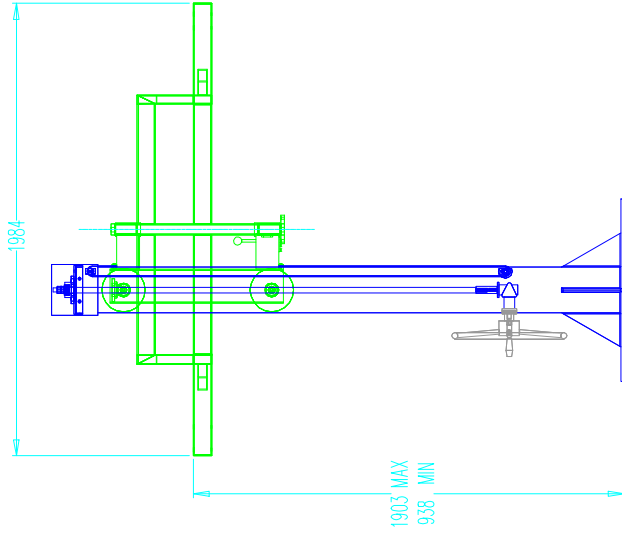
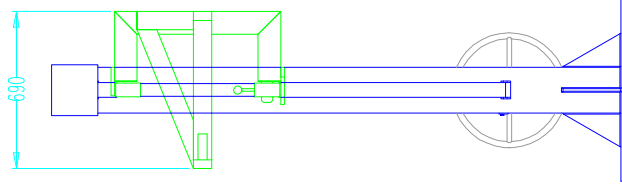
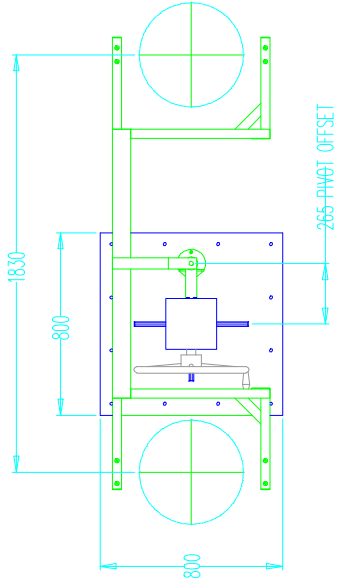
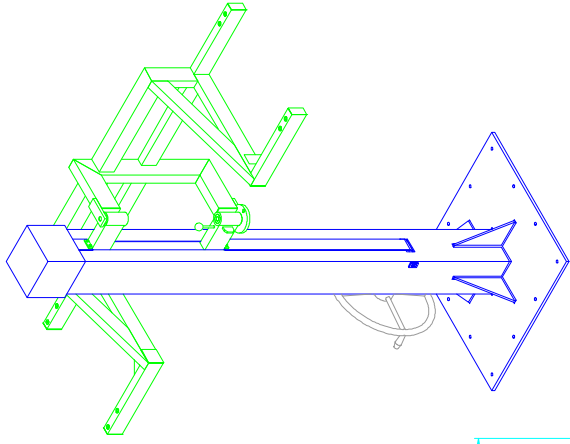

REMOVE ALL BURRS AND SHARP EDGES	
TOLERANCES : UNLESS OTHERWISE STATED	
FABRICATIONS : +/- 2.0mm	
MACHINING : +/- 0.2mm	
SHEET METAL WORK : +/- 1.0mm AND +/- 1.0 DEG	
DRAWN	CHECKED
D.J.P	DATE
	17-01-06
DRAWING NUMBER	
BP 3063-1A	

DRAWING TITLE	
SINGLE COLUMN MANUAL DOUBLE HOPPER LIFT	
REVISION NUMBER	CUSTOMER

COPYRIGHT RESERVED
 DRAWN THIRD ANGLE PROJECTION

BASE HANDLING PRODUCTS LIMITED
 UNIT 20 BARLETFIELD INDUSTRIAL ESTATE,
 BRYNMAWR,
 Gwent, NP23 4TF
 TEL: (01495) 312172 FAX: (01495) 312089 EMAIL: info@baseproducts.co.uk