

## Mixer Lift

### Ytron-Quadro Mixer Lift & Bypass

MML/150/400-1400/B

#### Mixer Lift & Bypass Description

This mixer lift is a manually operated lift that is designed to lift and lower a Ytron Mixer and Bypass. It is constructed from Grade 304 stainless steel box section and is fully TIG welded throughout. The mixer lift arm is raised and lowered via a manual winch handle and screw with a lowered height of 400mm and a raised height of 1400mm to allow the mixer to clear the drum in the full up position. To ensure a safe system of operation, there were two Spring Actuated limit switches either side of the drum location position. There was a further sensor to sense that the mixer lift was in its lowered position. The Mixer will only run once both bin location switches and the lift sensor are operated. The mixer lift is designed to be bolted to the floor.



*Ytron Quadro Mixer Lift*

Call now on **01495 312 172**

[webenquiry@basehandling.co.uk](mailto:webenquiry@basehandling.co.uk)

Base Handling Products Limited, Unit 20, Barleyfield Industrial Estate  
Brynmawr, Gwent, NP23 4YF.



**Mixer Lift Specification**

DESCRIPTION	YTRON-QUADRO MIXER LIFT
MODEL No.	MML/150/400-1400/B
CAPACITY	150 Kgs
MINIMUM HEIGHT	400mm
MAXIMUM HEIGHT	1400mm
STROKE	1000mm
BASE ARRANGEMENT	BOLTED TO THE FLOOR
CONTROL CIRCUIT	24Vac (STANDARD)
ELECTRICAL RATING	IP65
LIMIT SWITCHES	ADJUSTABLE ROD

**Mixer Lift Application Story**

This powder transfer system was required to vacuum transfer powders from a bag or bin into a vacuum transfer hopper. Once in the vacuum transfer hopper, the powders were fed into the solution via the bypass tube so that they were released directly into the mixer impeller giving a very efficient mix. The component parts of the powder transfer system were all fixed to a mobile base frame and this base frame was fitted with a pneumatically operated lift system. This lift allowed the transfer hopper and mixer to be lifted clear for a drum to be loaded for mixing.

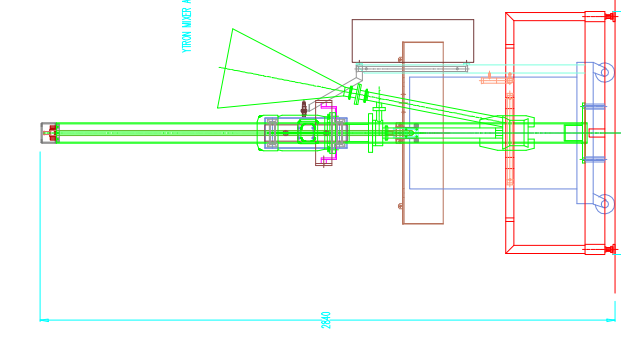
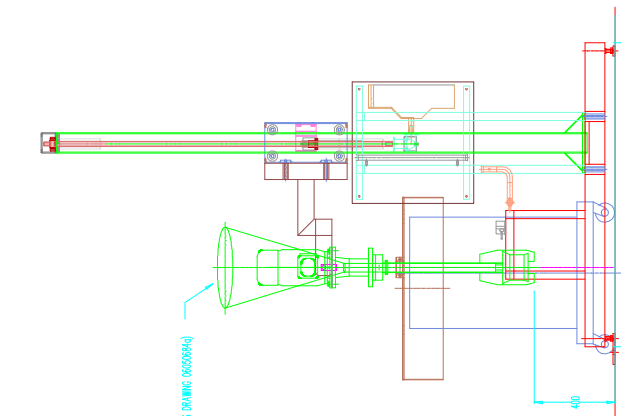
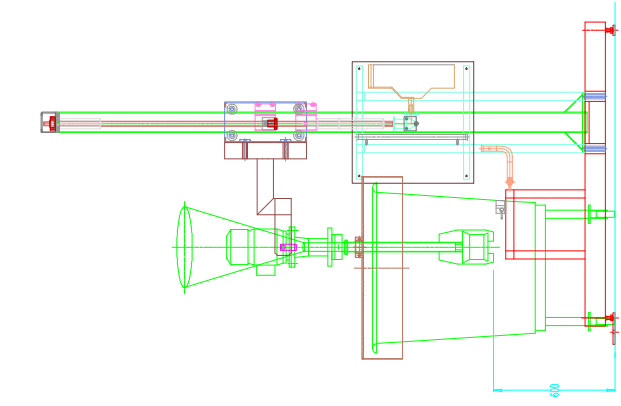
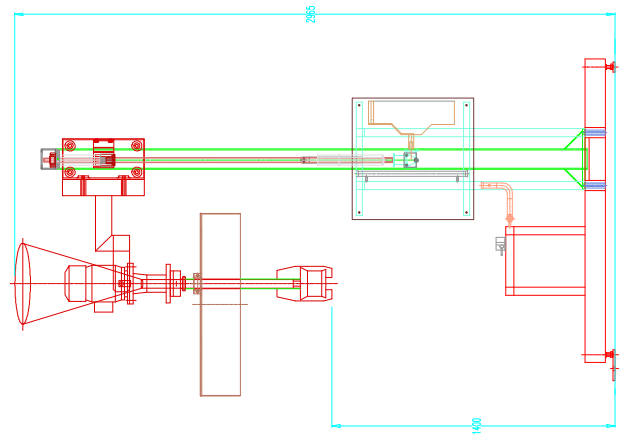
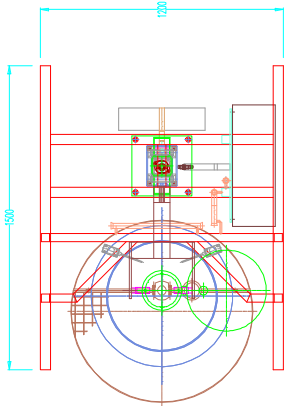

TRON MIXER AND BYPASS (AS DRAWING 00552664)

MIXER IN FULL UP POSITION

MIXER IN LARGER VESSEL

MIXER IN SMALLER VESSEL

REMOVE ALL BURRS AND SHARP EDGES	
TOLERANCES : UNLESS OTHERWISE STATED	
FABRICATIONS : +/- 2.0mm	
MACHINING : +/- 0.2mm	
SHEET METAL WORK : +/- 1.0mm AND +/- 1.0 DEG	
DRAWN	CHECKED
JPW	DATE
	10.06.06
DRAWING NUMBER	
BP3121-1	

COPYRIGHT RESERVED  
 DRAWN THIRD ANGLE PROJECTION



**BASE HANDLING PRODUCTS LIMITED**  
 UNIT 20 BARLEFIELD INDUSTRIAL ESTATE,  
 BRYNMAWR,  
 Gwent, NP23 4TF  
 TEL: (01495) 312172 FAX: (01495) 312089 EMAIL: info@baseproducts.co.uk

REVISION NUMBER	CUSTOMER
DRAWING TITLE	
YTRON QUADRO MIXER & BYPASS LIFT	