

Guarded Bin Tipper

Guarded Bin Tipper for 600 Litre Dolaf Bins BTH/600/1000/B/G

Guarded Bin Tipper Description

This guarded bin tipper is designed to lift and tip a 600 Litre Dolaf bin at a height of 1000mm. The guarded bin tipper is constructed from Grade 304 stainless steel and is a fully TIG welded construction throughout. This guarded bin tipper would be powered via a hydraulic powerpack and would tip the containers by the extension of a pair of stainless steel hydraulic cylinders. The guarded bin tipper will operate on a 'dead mans handle' principle and is designed to be bolted to the floor. The hydraulic cylinders will be fitted with hydraulic fuses to prevent the bin from falling in the unlikely event of a hose failure.



Guarded Bin Tipper for 600 Litre Dolaf Bin

Call now on **01495 312 172**

webenquiry@basehandling.co.uk

Base Handling Products Limited, Unit 20, Barleyfield Industrial Estate
Brynmawr, Gwent, NP23 4YF.



Safety Guard to PD 5304:2005 Safety of Machinery

The safety guard is constructed from 40 x 40 x 3mm stainless steel box section and 3mm wire, 40mm aperture stainless steel weld mesh to meet the requirements of PD 5304:2005 Safety of Machinery. It would enclose the guarded bin tipper to a height of 2200mm on two sides, 800mm at the front with a hinged door on the fourth side. The guard door is electrically and mechanically interlocked preventing the guarded bin tipper from operating with the door open. In addition, the guard door can only be opened when the lifting carriage is at the full down position.

Guarded Bin Tipper Specification

DESCRIPTION	HYDRAULIC GUARDED BIN TIPPER
MODEL NO.	BTH/600/1000/B/G
CAPACITY	600Kgs
TIPPING HEIGHT	1000mm
TIPPING ANGLE	120 DEGREES
MACHINE HANDING	LEFT OR RIGHT HAND AVAILABLE
TIPPING CHUTE	OPTIONAL
CONTAINER DESCRIPTION	600 LITRE DOLAF BIN
BASE ARRANGEMENT	BOLTED TO THE FLOOR
CONTROL CIRCUIT	24Vac (STANDARD)
ELECTRICAL RATING	IP65
POWERPACK	415V, 50 Hz, 3 PHASE & NEUTRAL

Guarded Bin Tipper Application Story

This fully guarded bin tipper was loaded with a Dolaf bin via a hand pallet truck and tipped the contents of the bin onto a sorting table. The tipping operation was fully automated such that a bin could be loaded, the safety gate closed and a cycle 'Start' push button pressed. The guarded bin tipper then lifted to full up, paused to allow the entire product to exit and then returned to the full down position.

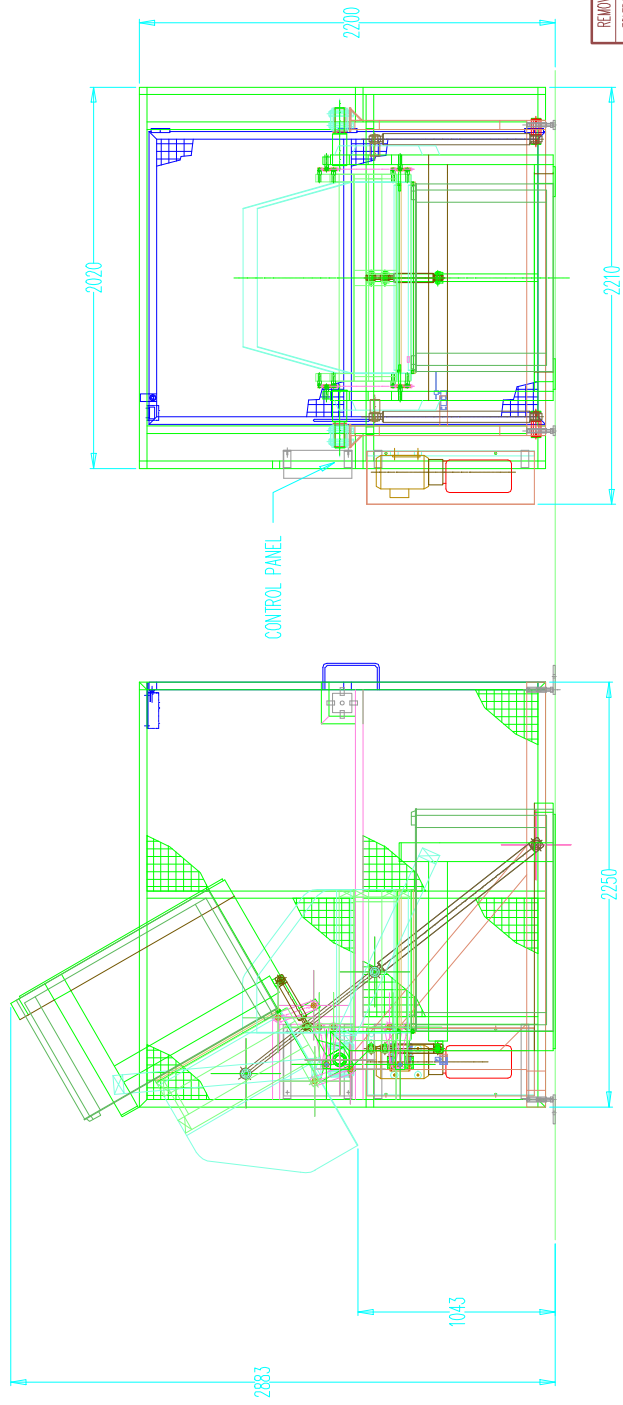
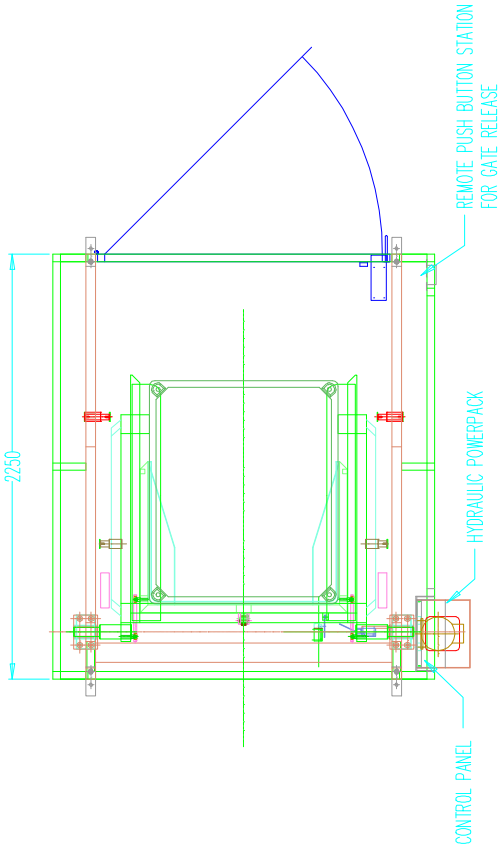

COPYRIGHT RESERVED

DRAWN THIRD ANGLE PROJECTION



BASE HANDLING PRODUCTS LIMITED
 UNIT 20 BARLEFIELD INDUSTRIAL ESTATE,
 BRYNMAWR,
 Gwent, NP23 4YF
 TEL: (01495) 312172 FAX: (01495) 312089 EMAIL: info@baseproducts.co.uk

REVISION NUMBER
 CUSTOMER

DRAWING TITLE

HYDRAULIC 600 LITRE DOLAF BIN TIPPER
 BOLTED GUARDED

REMOVE ALL BURRS AND SHARP EDGES
 TOLERANCES : UNLESS OTHERWISE STATED
 FABRICATIONS : +/- 2.0mm
 MACHINING : +/- 0.2mm
 SHEET METAL WORK : +/- 1.0mm AND +/- 1.0 DEG

DRAWN
 CHECKED
 DATE
 09-09-04

DRAWING NUMBER

BP2845-1