

Mobile Bin Tipper

Single Pillar Mobile Bin Tipper for 200 Litre Tote Bins BTM/250/1800/M

Mobile Bin Tipper Description

The mobile bin tipper is a single pillar 200 Litre tote bin tipper that is designed to lift and tip at a discharge height of 1800mm. The mobile bin tipper is constructed from Grade 304 stainless steel, is fully TIG welded throughout and will operate on a 'dead mans handle' principle. Lifting with the mobile bin tipper is achieved by a 3/4" Simplex chain driven by a motor gearbox mounted at the top of the main column. The mobile bin tipper is designed to be mobile on two fixed and two swivel braked castors.

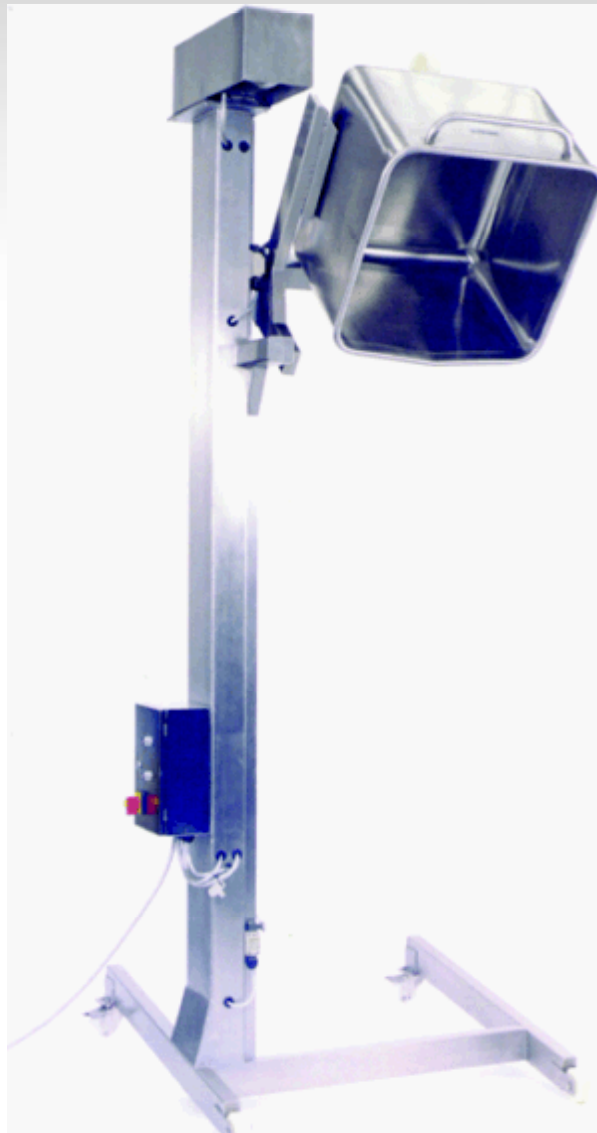

Mobile Bin Tipper for 200 Litre Tote Bins

Call now on **01495 312 172**

webenquiry@basehandling.co.uk

Base Handling Products Limited, Unit 20, Barleyfield Industrial Estate
Brynmawr, Gwent, NP23 4YF.



Mobile Bin Tipper Specification

DESCRIPTION	SINGLE PILLAR MOBILE BIN TIPPER
MODEL No.	BTM/250/1800/M
CAPACITY	250Kgs
TIPPING HEIGHT	1800mm
TIPPING ANGLE	130 DEGREES
OVERALL HEIGHT	2750mm
MACHINE HANDING	LEFT OR RIGHT HAND AVAILABLE
TIPPING CHUTE	OPTIONAL
CONTAINER DESCRIPTION	STANDARD 200 LITRE TOTE BIN
BASE ARRANGEMENT	MOBILE ON CASTORS
CONTROL CIRCUIT	24Vac (STANDARD)
ELECTRICAL RATING	IP65
LIMIT SWITCHES	ADJUSTABLE ROD
MOTOR DETAIL	0.55kW, 415V, 3 PHASE, 50 CYCLE
MOTOR BRAKE	415V SEPARATELY EXCITED
GEARBOX DETAIL	FLENDER D38 M1P4D7.5
OUTPUT R.P.M.	28 R.P.M.
RATIO	50:1
LOAD/TENSION CHAIN	¾" SIMPLEX DELTA Z
TENSILE STRENGTH	3000Kgs
LIFT SPEED	6.4 METERS/MINUTE

Mobile Bin Tipper Application Story

The mobile bin tipper is designed to lift and tip the contents of a 200 Litre tote bin into a grinder, mixer, blender or many other kinds of hoppers or vessels. This particular mobile bin tipper was used to lift and tip minced meat, bread crumbs and herbs into a blender/grinder to manufacture sausages.

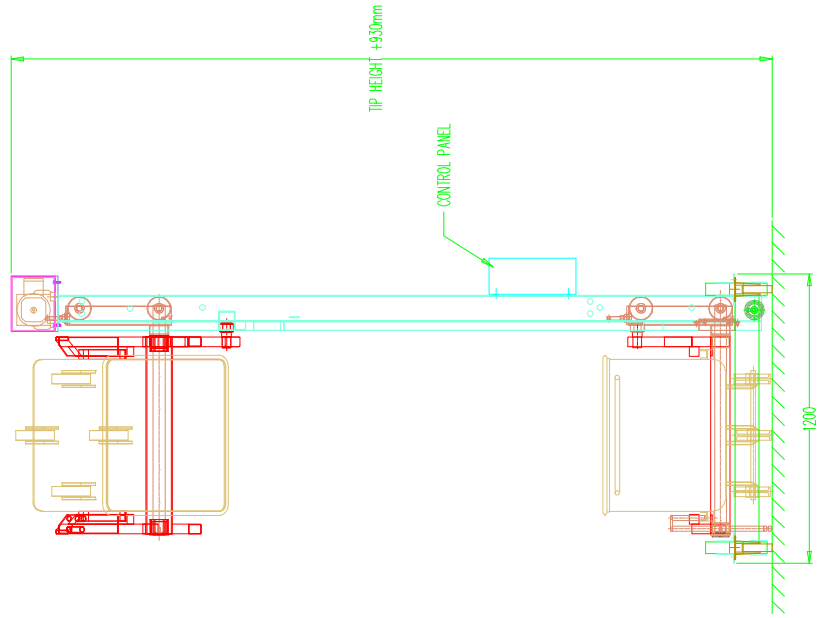
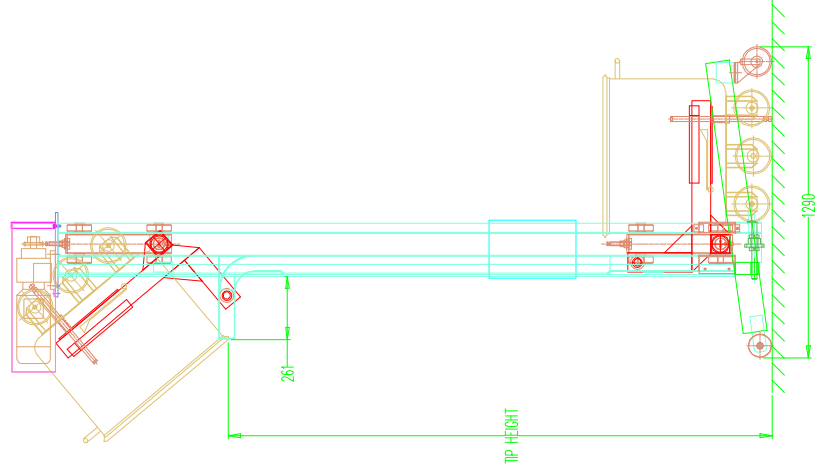
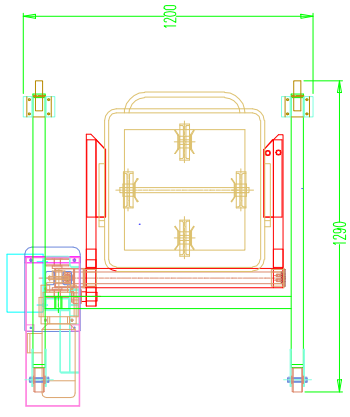

COPYRIGHT RESERVED
 DRAWN THIRD ANGLE PROJECTION



BASE HANDLING PRODUCTS LIMITED
 UNIT 20 BARLEFIELD INDUSTRIAL ESTATE,
 BRYNMAWR,
 GWENT, NP23 4TF
 TEL: (01495) 312172 FAX: (01495) 312089 EMAIL: info@baseproducts.co.uk

REMOVE ALL BURRS AND SHARP EDGES TOLERANCES : UNLESS OTHERWISE STATED FABRICATIONS : +/- 2.0mm MACHINING : +/- 0.2mm SHEET METAL WORK : +/- 1.0mm AND +/- 1.0 DEG	
DRAWN JPW	CHECKED DATE 09-05-05
DRAWING NUMBER BP1124-1A	

REVISION NUMBER	CUSTOMER
	SINGLE PILLAR 200 LITRE TOTE BIN TIPPER MOBILE
DRAWING TITLE	